

Flying Universal Gripper

T. MacMannis, CSE, P. May, CSE, N. Smith, EE, and Z. Roy, EE

Abstract—The Flying Universal Gripper is a novel way of retrieving objects with a UAV. This is achieved by outfitting a hexacopter drone with an advanced gripping system that is capable of picking up small objects of virtually any shape. The system is designed to utilize camera tracking software in real time to locate and navigate to desired objects from the the air. After identifying an object, the system autonomously lands above it, lowers to pick it up off the ground, and then flies to a predetermined location.

I. INTRODUCTION

An issue with drones today is that they are limited in their uses. Besides flying, drones are most commonly used for photography and aerial videos. We want drones to be more versatile. One way to do this is to enable drones to easily and accurately pick up and move objects. Designing a drone capable of automatically picking up objects would allow drone enthusiasts the ability to give drones a bigger impact on our everyday life. Our solution to this problem is to attach an gripper to a customized drone that allows it to automatically pick up objects.

There are several ways to pick up objects with drones. The mantis drone claw is one such example [1]. The mantis claw attaches to the drone by a wire and operates with the the force of gravity to pick up objects. As the claw is lowered onto an object the claw opens and forms around an object. When the drone lifts back up and applies tension to the wire, a gripping force is then transferred to the claw, picking up the object. Although it may appear as a successful design at first, there are many disadvantages to using this type of solution. First, since the drone is required to stay in the air as it attempts to lower the claw upon the object, the device is very susceptible to wind and slight movements from the drone as it hangs below. This means the pilot, or autonomous control system, would have to account for the swinging of the device and try to time its descent to make contact with the target object, an incredibly difficult problem to solve. Second, there is no way to release the object once it has been picked up without relieving the tension in the wire. This means that the claw must rest on the ground in order for the object to be released from the devices grip, making mid flight releases of the claw impossible. Finally, the structure of the claw limits the range of objects it can pick up. For example, flat objects would be impossible for the mantis to pick up and grasp.

Our solution to this problem is to equip a drone with a new type of gripping device that employs a phenomenon called

granular jamming. This gripping device can form around the shape of any object it makes contact with, increasing the range of objects that can be retrieved. Unlike the Mantis Drone Claw, something as rigid as a mug or as delicate as an egg can be handled with ease. Our system will be able to land, lower the gripper, and successfully acquire all types of objects.

This system has the potential to be applicable to many modern day fields including military, construction, and day to day search and retrieve applications. Apart from these direct applications, this system will be filling a gap in current drone technology, pushing forward the field and inspiring new, not yet thought of drone applications.

In order to make this drone a viable solution it must meet a few specifications. A minimum of a 20 minute flight time allows multiple trips per charge and enough time to accurately search for objects on the ground. It also must be able to lift up to five pounds, ensuring it has the ability to handle a wide range of objects. The total mass of the entire system should be less than 5.5 pounds, roughly half of the maximum thrust of the 6 motors. The cost should be less than \$500 which keeps it in budget as well as remaining a affordable solution that can be inexpensively deployed in different scenarios. Table 1 lists the specifications mentioned.

SPECIFICATIONS	
Specification	Value
Average Flight Time	20 minutes
Lifting Capacity	5 lbs.
Total Mass	5.5 lbs.
Cost	< \$500

Table 1

II. DESIGN

A. Overview

There are several methods capable of picking up a variety of shaped objects remotely. One method is to use a remotely operated ground based vehicle, because it would be easy to pick up and store objects. However it would be significantly more difficult to find objects due to either sloped terrain or other objects obscuring its view. This would make searching for an object undesirably slow. Our method is to build a remotely operated, flying drone with the capability to secure objects using a gripping device attached below. A drone can quickly and easily navigate to coordinates on the ground while

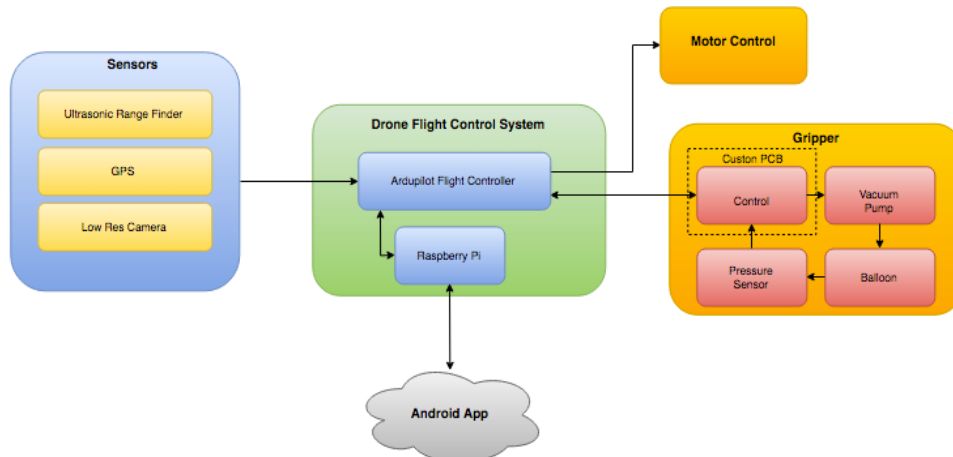

Figure 1 System Block Diagram

maintaining a set altitude. While flying, the drone has a good view of the ground below. Taking advantage of this, a downward facing camera mounted to the drone will be able to identify specific objects. The best way to control and monitor the flight of a drone would be to use a mobile app that relays flight information back to the user as well as allowing mission updates to be sent back to the drone.

Our design incorporates five main systems as shown in Figure 1. The first subsystem is our range of sensors. Each is used to relay vital information such as GPS coordinates and altitude back to the flight controller, Raspberry Pi, and operator. There is also the camera in this section, which is used to take aerial video for the computer vision object tracking.

The next block is the flight control system. This subsystem is comprised of an Ardupilot flight controller and a Raspberry Pi. The Ardupilot is the drone's central flight control system; it controls the speed of the individual rotors, in turn controlling the pitch, roll, yaw, and speed of the drone. The Ardupilot will relay information such as speed and location to a Raspberry Pi which will then update an Android app via WiFi. The Raspberry Pi will also perform image analysis based on the video coming from the downward facing camera. After analysis, specific directional commands will be relayed to the Ardupilot guiding it over a target object as it descends.

The Android app will enable specific parameters to be set for the drone, such as search pattern, return to home location, altitude and speed. The set home parameter would save the current GPS location of the drone, allowing the drone to navigate back to a safe location after either finishing a mission or in the event of a system malfunction. The search pattern changes the way the drone moves as it performs a search for a desired object on the ground. For example, a circular spiral approach could be implemented starting at a predetermined central location and slowly growing in radius as it gets further from the center.

The next block is flight hardware. In this block, we have six motors to provide a large total thrust, batteries for longer flight time, and a frame. We have provided a sturdy, modular frame which allows us to change the locations of our batteries, sensors, and the gripper.

The last block is the gripper attachment, depicted in Figure 3. This will be used to pick up the object. In this section we have the gripper and a series of PVC piping and flexible tubing that

connects the gripper to the vacuum. When an object applies enough pressure to the gripper, the vacuum will switch on, grabbing the object. With the object securely in place, the drone will then be able to safely take off and continue flight.

B. Drone System Overview

First, the design choices and hardware that make up our aircraft will be explained. We decided to purchase a hexacopter frame for this design instead of the typical quadcopter setup. This was done to gain the thrust that the extra two motors would bring, bringing our total to six motors [2]. The frame is extremely tough and able to take repeated hard landings, while at the same time still provide enough dampening to keep vibrations as low as possible. The motors used on this frame are the Crazepony Emax 935KV brushless motors rated up to 14.1V. The 935KV rating means that for every volt applied to the motor, its revolutions per minute (rpm) will increase by 935, giving us around 10,400rpm [3]. The propellers used are 10x4.5, meaning each one is 10 inches in length with a pitch of 4.5 inches. We decided to avoid carbon fiber propellers and stay with plastic as they are much safer to be around and are ideal while the design is still in testing. At max voltage each motor is capable of pushing out around 1.8 pounds of thrust, bringing the total thrust of the aircraft to 11.2 pounds. With our gripper attached the total weight of the aircraft comes out to 5.5 pounds about 50 percent of the max thrust. This is an ideal weight to thrust ratio that is perfect for long stable flights.

Each motor receives a control signal from an ESC, electronic speed controller, that it is paired up with [6]. The ESCs interpret signals sent from the flight controller and dictate how much power to send from the battery to the motors at a rate of 600Hz. This fast refresh rate allows for the motors to be constantly adjusting and stabilizing based on the environmental conditions and user input.

At the center of the frame is the onboard flight controller, the APM v2.6. This board utilizes a 3-axis gyroscope, accelerometer and a barometer [4]. It is also based on the Arduino Mega architecture, making the source code very accessible and easy to modify. A Raspberry Pi 3 is also onboard to handle interactions between the aircraft and the pilot via a cellphone app. The Raspberry Pi will also process a live video feed detecting if an object has entered the view of the camera

[5]. The entire aircraft is powered by a single 5000mAh 14.1V lithium polymer battery that is distributed to each of the ESCs. The flight controller and Raspberry Pi receive their required 5v from a Battery Elimination Circuit (BEC) that is wired directly to the battery that provides a constant 5v output at 3A [6]. This device saves us from having to use a second lower voltage battery and also provides a very clean power source to the onboard electronics. In order to prevent overheating we decided to not use the typical setup of having the BEC integrated into the ESCs themselves.

C. Sensors: GPS, UltraSonic, Camera, Pressure

Implemented on our drone system will be four sensors, a GPS, an ultrasonic range finder, a pressure sensor, and a camera. Each system is designed to serve a different and specific task that is crucial to the successful operation of the complete drone system.

Starting with the GPS unit, we used the NEO-M8N GPS module with built-in compass that interfaces directly with the APM flight controller board. This GPS offers less than 2 meter accuracy as well as an included compass, removing reliance on the built in compass on the APM board [7]. This is very important as the built in compass is surrounded by massive amounts of electromagnetic distortion making an accurate heading reading nearly impossible. Since the GPS unit sits around 6 inches above the entire frame, there will be drastically less interference and acceptable readings from the compass will be possible [8]. The GPS's main function will be to allow the drone to fly in set search patterns set by the user as well as allow the drone to return home or to fly to any destination to land.

The next sensor is an ultrasonic rangefinder for precise altitude hold and readings. The sensor that will be used is the MB1010 LV-MaxSonar-EZ1 range finder with a resolution of 1" from 0" to 254", or about 21 feet [9]. This sensor will allow extremely accurate readings of the drone's current altitude. The drone will be flying at a low altitude in order to spot objects on the ground with its camera. If for some reason the drone needs to reach an altitude above the specifications of the sonar sensor the barometric sensor onboard the APM will be used instead [10].

A low resolution camera will be installed on the bottom of the drone facing downward. The camera will continuously output 1000TVL definition video to the Raspberry Pi for image analysis [11].

The last sensor used on this system is a pressure sensor placed on the inside of the granular jamming gripper that can measure the force being applied. The sensor is a force sensitive resistor that can read accurately up 22lbs and as little as 1 oz. This sensor works by simply varying the resistance between 2 pins as force is applied to the flexible pad [12]. A change in voltage can then be read by a microcontroller as the resistance level changes. This sensor allows our gripper the ability to know when it has come into contact with an object and to start the vacuum. This sensor is a part of the PCB portion of the system and is directly connected to the overall gripper system.

D. Autonomous flight

In order to achieve autonomous flight we will employ GPS aided flight patterns and camera tracking techniques to guide the drone. Using the android app the operator will be able to set a search flight pattern within a specified area. The drone will use its GPS unit to fly in that search pattern while continuously streaming video data of the ground to the Raspberry Pi. The Raspberry Pi computer, operating at 1.2GHz and 1GB of RAM, will process the video data using image processing techniques[13]. To recognize an object we will paint it a special color and use a color tracking algorithm to identify it. The color tracking software will be implemented in Python using Open CV's open source computer vision platform [14]. Since we are locating a stationary object the color tracking will be significantly simplified compared to other drone projects which normally attempt to track a moving target. When the object has been identified by the Raspberry Pi, it will notify the flight controller. In order to fly to the object a path planning algorithm will be used. The path planning algorithm's goal is to land the drone on top of the object so that its gripper system can then take over. The flight path to the object will be calculated by the object's relative pixel location in the video feed, the drone's current GPS coordinates, and the drone's altitude. These inputs will continuously update the algorithm in a feedback loop in order to land the drone as centered on the object as possible. The output of the algorithm is flight commands to the rotors.

E. Universal Gripper

The gripper subcomponent of our project employs the phenomenon of granular jamming. The concept of granular jamming uses a mass of granular material enclosed in an elastic membrane to form a gripper. By applying positive and negative force to the gripper it is able to pick up a variety of objects. The negative force comes from a vacuum, while the positive force comes from inserting air into the system [15]. To pick up an object, first the gripper descends down on top of the object and molds around its surface. Second, using a vacuum, a negative air pressure is applied inside the gripper making the granular material solidify, giving it a very firm grip on the object. Given the shape of an object, the gripper may apply force in three ways, demonstrated in Figure 2. Normally the gripper will apply friction force upwards on an object in a pinching fashion. However, given the geometric shape of the object, the gripper may be able to grab under its curves and bends. Also if the object is round the gripper may be able to create an airtight seal providing a complimentary suction force. To release the object air is pumped back into the gripper, which will loosen its firm

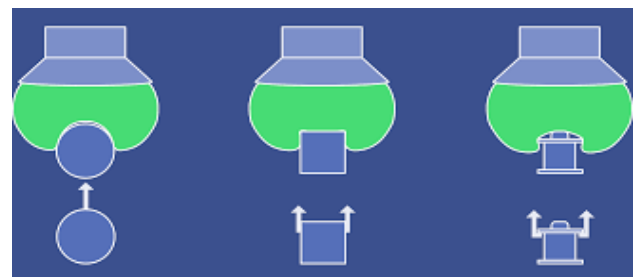

Figure 2 Gripper Configurations [16]

grip, and the object will be released.

To build the gripper for our project we picked out a sturdy elastic membrane and a granular material. We decided to go with an 18" balloon for the elastic membrane and fine coffee grounds for the granular material. The reason for this was both items were readily available and inexpensive. We tested out three balloons with varying diameters, 8", 14", and 18", to find out which size was the most versatile in picking up an assortment of objects. After testing the three balloons, we found that a larger balloon is overall the best option as it has more material to form around and grip objects. Table 2 shows the

Balloon Size	Egg	Scissors	Pen	Mug	Stapler	Plate	Hedge Clippers
8"	No	No	Yes	Yes	No	No	No
14"	Yes	No	Yes	Yes	No	No	No
18"	Yes	Yes	Yes	Yes	Yes	Yes	Yes

Table 2 Gripper Results

results of the tests conducted for each balloon size. We tested the balloon with various amounts of coffee grounds and found that filling the deflated balloon one third of the way full worked the best. By filling the balloon only a third of the way we were still able to easily mold around objects and there wasn't so much coffee where it would not get a proper grip.

After the balloon was filled, we used a funnel to hold the balloon. The funnel was chosen for the same reason as coffee and the balloon, it was available and inexpensive. We ran the neck of the balloon through the stem of the funnel and the base of the balloon was held in the mouth of the funnel. We cut both sides of the funnel so the balloon could more easily fit inside of it. Since we were going to be applying suction to the balloon we needed a way to stop the coffee grounds from being sucked up. We decided to add a piece of cloth over the stem of funnel to act as a filter. It would let air in and out but would keep all the coffee grounds in the balloon.

The next step after building the gripper was to find a suitable vacuum for the drone system. The vacuum had to be as small and as light as possible while still applying enough negative pressure to the balloon to cause the granular jamming effect. Also, keeping the weight down as much as possible is very important so that the overall weight the drone needs to lift is lower. After searching we decided to use the Karlsson Robotics 12V Vacuum Pump [17]. We chose this pump because it was very compact and relatively light. It runs on 12V and only draws around 1 amp of current, which also worked well for us because the battery we used was 12V [18]. The pump exceeds our requirement for suction strength, providing quick negative pressure to the balloon allowing even very heavy objects to be picked up.

Now that we had the gripper and the vacuum pump the last step was to connect them. The vacuum pump had a small opening where tubing could be attached. We decided to use a 1/8" flexible tubing to connect to the pump. The flexible tubing allowed us to freely place the pump wherever we wanted. To connect the tubing to our gripper we used a series of connectors. We found a 1/8" to 1/2" metal connector. We attached the

tubing to the 1/8" side and connected the 1/2" side to a PVC pipe. The PVC pipe was cut so it was 3" in length. The other side of the PVC pipe was connected to our gripper. We put the stem of the funnel into the PVC as far as it could go and then fastened the connection. With the connections in place the gripper subsystem was completed. Figure 3 shows the assembled gripper.



Figure 3 Gripper Fully Assembled

F. PCB/Mechanical Feedback System

Our system will utilize a custom PCB board illustrated in Figure 4 that will contain hardware to control the gripper system, landing gear, and pressure sensor as well as communicate to and from the ardupilot.

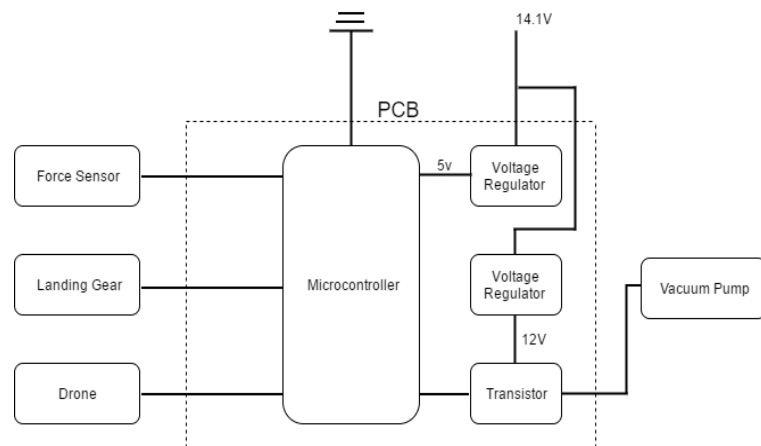

Figure 4 PCB Components

We are planning on creating a feedback loop. Once the drone lands on the ground, the microcontroller on board the PCB will send a PWM signal to lower the landing gear until the pressure sensor detects an object in the gripper. Next the microcontroller will signal a transistor to turn on the vacuum pump to pick up the object.

The first step in the feedback loop is implementing retractable landing gear. Once the drone has landed, it will rest on the landing gear. We plan to modify the landing gear by adding wheels to it. This will allow the drone to slowly lower onto the object. We can slowly retract the landing gear and as we do this

the wheels will spread farther apart lowering the drone. As the drone slowly lowers the gripper will firmly come into contact with an object.

The pressure sensor is the next step in the feedback loop. The pressure sensor is able to detect when the gripper made contact with an object. As the landing gear is lowering the microcontroller will check the values coming from the pressure sensor. Once a certain threshold is reached it will be determined that the right amount of pressure is being applied to the object and the lowering can stop. Lastly, the microcontroller will turn the vacuum on and signal the ardupilot to take off.

III. PROJECT MANAGEMENT

MDR Deliverable	Completion
• Drone assembled and tested	100%
• Functional gripper built and tested	100%
• Integrated drone and gripper prototype	100%
• Demonstration of picking up object remotely	100%
• Design beta app	100%

Table 3 Status of MDR Goals

We have successfully completed our proposed MDR deliverables. Over the past three months we have built a flying drone, constructed a functioning gripper unit, and integrated the two systems into a working prototype shown below.



Figure 5 Assembled System

We have also designed an android app to display feedback from the drone once we incorporate various sensors. The list of our completed deliverables is outlined in Table 3. Through hard work and diligence our team has reached our preliminary goals and we are excited to complete the second half of the project. There are still many hurdles to to overcome. Moving forward, we need to combine two major subsystems into our design: autonomous flying and gripper reliability. Along with these systems we need to integrate a suite of sensors that will let the drone sense its environment. Relaying feedback from the sensors to the operator will require interfacing the drone to our app through a Raspberry Pi. These tasks have been broken up evenly amongst our team based on individual expertise and

natural progression from MDR. The breakup and schedule are shown in the following Gantt chart.

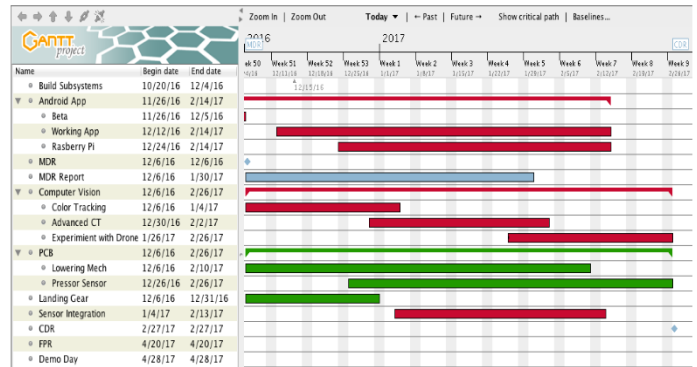

Table 4 Gantt Chart

We could not have asked for a better team. Each of us works hard and brings unique views and experience to the table. Peter is a Computer Systems Engineer who works at BlueRISC, a system security solutions company. There he has gained relevant knowledge of android and linux systems and first hand experience of the software design cycle. Peter is the team manager and is responsible for interfacing the Raspberry Pi and android app and developing camera tracking software. Tim is a Computer Systems Engineer who works at EMC, a cloud storage company. He has gained experience building and operating drones after working for an aerial media company out of Worcester Massachusetts. Tim is responsible for drone design and sensor integration. Noah is an Electrical Engineer who has experience working with circuits and electronics through projects and labs. Noah is responsible for the PCB integration with the gripper sub-system. Zach is an Electrical Engineer and is responsible for implementation of the landing gear and pressure sensor Zach also has experience working with circuits and electronics through projects and hobbies. He also has experience working with feedback and control systems.

Our team works well together and we conduct face to face meetings at least twice a week. Each meeting is well organized and productive. When a member cannot make a scheduled meeting we make a outline of our discussion so that they can catch up. We also hold Skype video calls when meeting in person is not necessary. Our team is in constant communication with each other through means of a group text conversation or Facebook messenger. Sharing documents and presentations on Google has been invaluable, allowing any and all group members to update our results/reports remotely. Under the supervision of Professor Gong, our team has remained committed and effective in the development of our project.

IV. CONCLUSION

As of MDR, we have a gripper system, without the PCB and sensor feedback, built and functional. We also have our drone assembled. We have combined the drone and gripper into a basic prototype. This prototype has a gripper system mounted underneath the drone, and a battery and vacuum on top to help balance the weight. We also have a remotely operated switch

which controls the vacuum, so we can activate the gripper while flying the drone. Through integrating the drone and the gripper, we have been able to see flaws in our original design. It has helped up to see areas that will need improvement, along with areas that work better than expected.

The major areas that need our current attention are gripper reliability, autonomous flight, sensor integration, and app implementation. With the drone and gripper assembled, these are the next areas of focus.

When testing our original design we experienced minor set backs. It was very difficult to keep the drone hovering over an object while applying the downward pressure needed to pick up an object. To solve this problem we are adding modified landing gear to our drone. The modified landing gear will be able to lower the drone body onto the object so that the gripper may grasp the object. On the ground, we will have a significantly more stable system and it will be easier to pick up an object. Then we will implement a pressure sensor to detect when the drone has dropped low enough to pick up the object. The pressure sensor will be controlled by a PCB which will in turn, initiate the vacuum pump and instruct the drone to resume flight. The lowering operation and PCB feedback system will be designed and tested by Zach and Noah.

To achieve autonomous flight, significant work needs to be done. First, we will connect the GPS unit to the drone and attempt to have the drone fly simple routes without user control; e.g. short straight lines). This will be difficult during the winter as outdoor conditions will not be favorable. The sonic ultra range finder will be added as well. Then the camera will be interfaced to the Raspberry Pi and we will begin to develop our image analysis algorithm to detect an object. Once we have both systems working, we will integrate them into a path planning algorithm to land on a specified target that is autonomously identified. Inspiration for the path planning will be drawn from past SDP projects and online open source projects. Tim will be responsible for the automated drone flight patterns and Peter will responsible for the camera tracking and path planning algorithms.

Finally, we are writing an app to control the drone's take off, program flight patterns, and display current flight diagnostics. The app will be written using Android Studio and will communicate over WiFi with the drone's onboard Raspberry Pi. This will help us troubleshoot issues that we may be facing with camera tracking and path planning.

REFERENCES

- [1] B. Kardoosh, "Mantis Drone Claw," in Kickstarter. [Online]. Available: <https://www.kickstarter.com/projects/465382488/mantis-drone-claw>. Accessed: Dec. 23, 2016.
- [2] M. Gortolev, "Quadcopter vs Hexacopter vs Octocopter: The Pros and Cons," in Dronebly, Dronebly, 2014. [Online]. Available: <http://dronebly.com/quadcopter-vs-hexacopter-vs-octocopter-the-pros-and-cons>. Accessed: Jan. 31, 2017.
- [3] O. Liang, "How to choose motor and propeller for Quadcopter," in OscarLiang, 2016. [Online]. Available: <https://oscarliang.com/quadcopter-motor-propeller/>. Accessed: Oct. 23, 2013.
- [4] "ArduPilot APM 2.8 flight controller board," in Unmanned Tech Shop, Unmanned Tech, 2016. [Online]. Available: <https://www.unmannedtechshop.co.uk/ardupilot-apm-2-8-flight-controller-board/>. Accessed: Dec. 23, 2016.
- [5] Amazon, "Corprit Mini HD 1000TVL CCTV FPV camera video recorder for Quadcopter QAV210/180/250," in Amazon.com, Amazon, 2016. [Online]. Available: <https://www.amazon.com/Corprit-1000TVL-Camera-Recorder-Quadcopter/dp/B01FEZV496>. Accessed: Feb. 1, 2017.
- [6] "What are ESC, UBEC and BEC," in OscarLiang, Oscar Liang, 2015. [Online]. Available: <https://oscarliang.com/what-is-esc-ubec-bec-quadcopter/>. Accessed: Feb. 1, 2017.
- [7] "NEO-M8 series," in u-blox M8 concurrent GNSS modules, 2016. [Online]. Available: https://www.u-blox.com/sites/default/files/products/documents/NEO-M8-FW3_ProductSummary_%28UBX-16000345%29.pdf. Accessed: Dec. 23, 2016.
- [8] "Advanced compass setup — Copter documentation," in Ardupilot, 2016. [Online]. Available: <http://ardupilot.org/copter/docs/common-compass-setup-advanced.html>. Accessed: Feb. 1, 2017.
- [9] "LV-MaxSonar@ -EZ™ Series High Performance Sonar Range Finder," in Maxbotix. [Online]. Available: http://www.maxbotix.com/documents/LV-MaxSonar-EZ_Datasheet.pdf. Accessed: Feb. 1, 2017.
- [10] "Analog sonar (AC3.1) — Copter documentation," in Ardupilot, 2016. [Online]. Available: <http://ardupilot.org/copter/docs/sonar.html>. Accessed: Feb. 2, 2017.
- [11] "420 TVL, 480 TVL, 540 TVL, 600 TVL, 700 TVL, 1000 TVL - what are tV-lines?," in Security Camera Warehouse, 2004. [Online]. Available: <https://www.security-camera-warehouse.com/knowledge-base/comparing-420-480-600-700-tv-lines-php/>. Accessed: Feb. 2, 2017.
- [12] "Force sensitive resistors (FSRs)," in Open Music Labs, 2016. [Online]. Available: <http://www.openmusiclabs.com/learning/sensors/fsr/>. Accessed: Dec. 23, 2016.
- [13] "Raspberry pi 3 model B," Raspberry Pi. [Online]. Available: <https://www.raspberrypi.org/products/raspberry-pi-3-model-b/>. Accessed: Feb. 9, 2017.
- [14] "OpenCV," in OpenCV, 2016. [Online]. Available: <http://opencv.org/>. Accessed: Dec. 23, 2016.
- [15] J. Amend, E. Brown, N. Rodenberg, H. Jaeger, and H. Lipson, "A Positive Pressure Universal Gripper Based on the Jamming of Granular Material," *IEEE TRANSACTIONS ON ROBOTICS*, Apr. 2012.
- [16] "VERSABALL," in Empire Robotics, 2014. [Online]. Available: <http://empirerobotics.com/>. Accessed: Feb. 8, 2017.
- [17] "Vacuum pump - 12V," in Karlsson Robotics, Karlsson Robotics. [Online]. Available: <http://www.kr4.us/vacuum-pump-12v.html>. Accessed: Feb. 2, 2017.
- [18] "Air Pump Series," in Spark Fun Electronics. [Online]. Available: <https://www.sparkfun.com/datasheets/Robotics/Other/spec%20sheet.jpg>.